

# STI Series 2000 Stopper® Stations



SS-2004



## FEATURES

- Unique, curved design helps protect against accidental activation.
- 5VA flammability rating on backplate and spacer.
- Station housing molded of super tough polycarbonate.
- Your choice of colors—red, green, yellow, white or blue.
- UL Listed to U.S. and Canadian safety standards (excludes “6” button).
- Raised standard or custom vinyl labeling.
- Typical working properties of polycarbonate are -40° to 250°F (-40° to 121°C).
- Wording in virtually any language.
- Polycarbonate complies with FDA regulations for food contact applications.
- Stainless steel backplate.
- Buttons with Mini Weather Stopper® cover, when mounted in accordance to manufacturer’s installation instructions on a smooth surface, provides a rain tight seal similar to a 3R rating.
- Push buttons are ADA Compliant (excludes “3” button).
- Three year guarantee against breakage of polycarbonate in normal use (one year on electro mechanical and electronic components).

## PRODUCT OVERVIEW

These ADA Compliant, multipurpose push-button switches cover a wide range of applications both indoors and outdoors. They’re called Stopper Stations. They incorporate a unique, patented design that helps dramatically to stop accidental activation. A number of standard models are available or we can create custom units to meet your needs exactly. You have your choice of any of five universal colors identifying switch usage, wording and language.

## HOW THEY WORK

Because of their superior, patented design combined with quality construction throughout, you can expect outstanding performance for years to come. In fact, many STI customers are surprised to find that all this quality is available at no increase in price. Plus, customers appreciate the option to protect the switches with STI protective covers that carry a three year guarantee against breakage in normal use, one year on electro mechanical and electronic components. For indoor applications, you can order your Stopper Station with a pre-alarm cover to help stop malicious and accidental activation.

# STI Series 2000 Stopper® Stations

## Dimensions and Technical Information

### UNIQUE BUTTON FEATURES

#### Models SS-2000F (FIRE)

- Standard switch includes two N.O. SPST gold plated contact blocks rated for 1 amp @ 250 VDC. Holds up to three sets of isolated contacts either N.O. or N.C. No backbox available.
- To increase depth to an existing standard single gang box (for contact clearance) use the STI-102722-R which adds 5/8" to box depth.

#### Models SS-2\*00, SS-2\*01, SS-2\*03, SS-2\*04

- Interchangeable or replaceable N.O. or N.C., SPST gold-plated contact blocks rated for 3 amps @ 600 VAC or 1 amp @ 250 VDC.
- Backbox available for 1, 3 and 4 buttons.
- Standard switch includes one N.O. and one N.C. contact. Holds up to three sets of isolated contacts.
- To increase depth to an existing standard single gang box (for contact clearance) use the STI-102722-color which adds 5/8" to box depth.

#### Model SS-2002F (Fire)

- Includes two Form "C" contacts rated at 7A @125/250 VAC.
- Backbox included when ordering with cover options: 0, 6, 7 or 8.

#### Model SS-2\*02, SS-2\*05, SS-2\*09

- 2 sets of Form "C" contacts rated at 10 amp @ 125/250 VAC, 1/2 HP 30 VDC, 6A.
- Backbox included when ordering with cover options: 0, 6, 7 or 8.

#### Model SS-2\*07

- Illuminated button Includes one Form "C" contact rated at 10A, 1/2 HP, 125/250 VAC, 6A, 30V. 28 volt incandescent lamp included (10A AC, 6A DC 3 volt).
- Backbox available.

#### Model SS-2\*06 (Not UL Listed)

- One N.O. contact, SPST, 24 VAC/DC 0.2A.
- Backbox included when ordering with cover options: 0, 6, 7 or 8.
- Sealed metal surface is virtually indestructible, vandal proof and easy to clean.
- No moving parts. Long life expectancy, no amortization.
- Life cycles over 50 million.
- Actuation force typically 3 - 5 N (8-11 oz.).
- External push force activates a Piezo element which releases voltage utilized for switching.
- Suitable for harsh environments: water and dust proof for indoor and outdoor use.

#### Model SS-2\*08

- Switch rating 10 amp. (resistive) 240 VAC and has a timer range: 2 - 60 seconds ( $\pm$  15%).
- Not recommended for outdoor/water applications, temperature range of button 15°F to 120° F (-9°C to +49°C).
- Timer life of over 1,000,000 operations.
- Backbox included when ordering with cover options: 0, 6, 7 or 8.
- Pneumatic adjustable timer opens or closes a circuit and has a timed delay before reset. No electricity to operate.
- Ideal for security applications.
- Two sets of isolated contacts, 1 N.O. and 1 N.C.

\*NOTE: Second digit designates color

### APPROVALS & WARRANTY

#### TESTING

It has been tested and approved or listed by:

- Underwriter Laboratories and Canadian Underwriter Laboratories No. S7255 (excludes "6" button). Complies with UL 2017. UL Listed for indoor and outdoor use (8" button indoor only, temperature range 15°F to 120°F). When mounting outdoor, must use an STI weather cover.
- ADA Compliant (excludes "3" button)

#### WARRANTY

Three year guarantee against breakage of polycarbonate in normal use (one year on electro mechanical and electronic components).

#### Accessories

- SUB-102722-Color** Plastic Spacer - Red, Green, Yellow, White and Blue for 0, 1, 3, 4 and 7 button type
- 19030** One Extra Key for 0 button type
- 18061** One Extra Key for 2 button type
- 10196** N.O. contact for 0, 1, 3 or 4 button type
- 10197H** Contact holder for 0, 1, 3, and 4 button type
- 10198** N.C. contact for 0, 1, 3 or 4 button type
- SUB-71100A-Color** Backbox - Red, Green, Yellow, White and Blue for 2, 5, 6, 8 and 9 button type
- SUB-71101A-Color** Backbox and Spacer Kit for 1, 3, 4 and 7 button type

#### "A" - Contact Depth

SS-2*00	2.25"
SS-2*01	2.25"
SS-2*02	1.25"
SS-2*03	2.25"
SS-2*04	2.25"
SS-2*05	1.25"
SS-2*06	0"
SS-2*07	1.5"
SS-2*08	1.4"
SS-2*09	1.25"

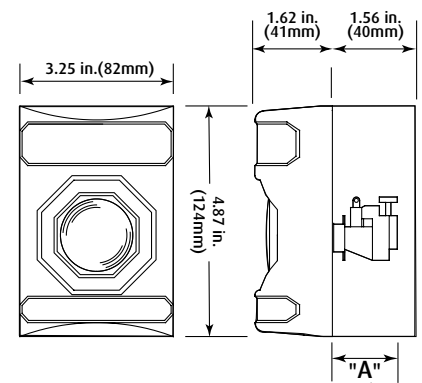

TO PROVIDE ADEQUATE CLEARANCE FOR CONTACTS, (#0, #1, #3, #4) INSTALLATION MAY REQUIRE: SUB-102722-COLOR SPACER

# STI Series 2000 Stopper® Stations

Dimensions and Technical Information

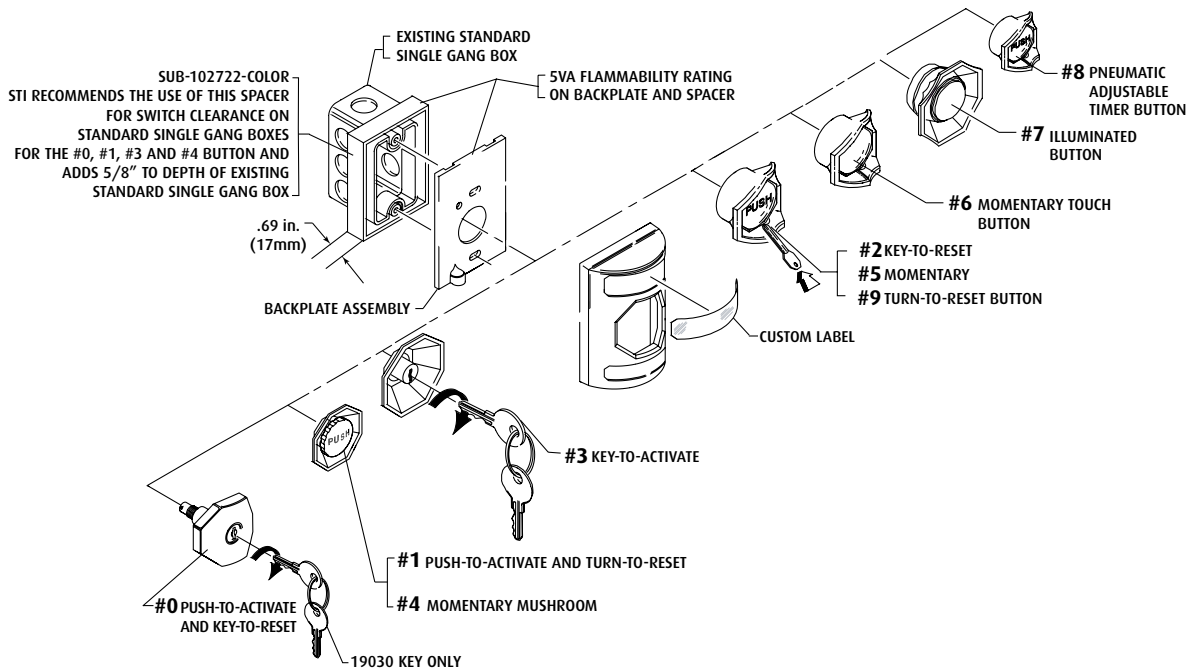

Covers to protect your STI Stopper Station from damage or weather and to help stop malicious or accidental activation.

## Mini Stopper® II

This smaller cousin of the famed Stopper® II helps stop false fire alarms and can protect your Stopper Station against damage indoors as well as malicious or accidental activation. It consists of a tamperproof, clear polycarbonate shield that fits easily over any STI Stopper Station model. When it is lifted to gain access to the Stopper Station, it sounds a piercing 105 dB warning horn. Legitimate activation is not affected. The protective cover is available with or without the optional horn. The virtually indestructible cover comes with a lifetime warranty in normal use. Custom labeling is available. **NOTE:** See separate spec sheet for complete cover details.



SS-2147X

## Bopper Stopper®

Now you can protect your indoor Stopper Station from vandalism or accidental activation with the STI Bopper Stopper. Both this protective cover and its hinges are molded of tough polycarbonate material so you know it will take hard knocks in stride. To help prevent corrosion, the hinge spring is formed from stainless steel. The combination of Stopper Station with a Bopper Stopper protective cover is for indoor use only. **NOTE:** No labeling can be placed on the Bopper Stopper cover. Need to order 102721 Adapter Plate when Stopper Station spacer SUB-102722-color is mounted under button. See separate spec sheet for complete cover details.



SS-2010F

## Mini Weather Stopper®

This tough cover, without a built-in alarm, is used to protect any STI Stopper Station from damage or the weather in outdoor use or indoor harsh environments. It is a less costly choice where malicious or false activation is not a problem. STI Mini Weather Stopper is ideal for environments such as those on oceangoing ships, oil rigs, beachfront condos, car washes or any area subjected to saltwater conditions. It is available in any of four colors for both flush and surface mount installations. Weather gaskets are included. Tested to NEMA 3R standards. **NOTE:** See separate spec sheet for complete cover details.



SS-2450

## Stopper® Station Shield

This inexpensive and high durable cover, without alarm, was invented to mount directly onto the Stopper Station series of buttons. With two tabs that snap into the Stopper Station, the cover easily mounts over the push button. It takes hard knocks in stride while protecting the button against vandalism, damage and accidental activation. Ideal for use when space is limited.



SS-2222PO

\*Please note it is mandated by UL that UL Listed Stopper Stations be protected with an STI Mini Weather Stopper when used outdoors.

# BUILD YOUR MODEL

SS-2

## STEP 1 - SHELL COLOR

**0** = RED  
**1** = GREEN  
**2** = YELLOW  
**3** = WHITE  
**4** = BLUE

## STEP 2 - PROTECTIVE COVER

**0** = No Cover  
**1** = Bopper Stopper® Cover \*  
**2** = Stopper® Station Shield  
**A** = Stopper® Station Shield w/sound  
**B** = Stopper® Station Shield w/sound & wireless ■  
**3** = Mini Stopper® II Cover without horn  
**4** = Mini Stopper® II w/horn  
**5** = Mini Weather Stopper® Cover ▲  
**6** = Mini Weather Stopper® Cover w/spacer ▲  
**7** = Mini Stopper® II Cover without horn w/spacer  
**8** = Mini Stopper® II w/horn w/spacer

All covers will read "LIFT HERE" at bottom, language specification available for custom label charge; not available without instruction.

\* For surface mount applications, the 102721 Adapter plate will be required.

■ B model requires receiver STI-34104 or STI-34108 receiver. ▲ Covers 5 & 6 not available with STEP 3, Button 8.

## STEP 3 - BUTTON/SWITCH ACTIVATION

**0** = Octagonal Button (Push-to-Activity, Key-to-Reset) \*  
**1** = Push and Turn-to-Reset \*  
**2** = Push and Key-to-Reset Octagon Button  
**3** = Key-to-Activate \*  
**4** = Momentary Mushroom \*  
**5** = Momentary Mushroom Octagon Button  
**6** = Momentary Touch Button (no UL Listing)  
**7** = Illuminated Mushroom (red or green)  
Green housing has green illuminated button.  
All others have red illuminated button.  
**8** = Pneumatic Adjustable Timer Button ●  
**9** = Push, Turn-to-Reset Octagon Button

All buttons will read "PUSH" or "PUSH HERE" (excludes #3 and #6), language specification available for custom label charge; not available without instruction.

● Button 8 not recommended for outdoor/water applications, temperature range 15°F to 120°F.

\* Buttons 0, 1, 3, 4 may require spacer SUB-102722 (color) to accommodate depth or a deep single-gang box.

## STEP 4 - RAISED MOLDED MESSAGE

The following messages are available only on color indicated. All colors can be custom labeled to your specifications. (See box at right.)

MESSAGE	AVAILABLE ON
<b>F</b> = "FIRE" (0 & 2 button only)	Red Shell
<b>E</b> = "EMERGENCY"	Red Shell
<b>PS</b> = "FUEL PUMP SHUT-DOWN"	Red Shell ◆
<b>X</b> = "EXIT"	Green Shell
<b>EX</b> = "EMERGENCY EXIT"	Green Shell
<b>E</b> = "EMERGENCY"	Blue Shell
<b>EX</b> = "EMERGENCY EXIT"	Blue Shell
<b>E</b> = "EMERGENCY"	Yellow Shell
<b>PS</b> = "FUEL PUMP SHUT-DOWN"	Yellow Shell ◆
<b>PO</b> = "EMERGENCY POWER OFF"	Yellow Shell
<b>PO</b> = "EMERGENCY POWER OFF"	White Shell

◆ Not available with pneumatic #8 button. \* Cover labeling only available for STEP 2, options 3-8.

**CUSTOMIZE YOUR TEXT** - Custom label available in black and white vinyl only. (Black is standard on white and yellow shell. White is standard on blue, red and green shell.)

CUSTOM LABEL FOR SHELL: 1 LINE, 13 CHARACTERS MAXIMUM  
2 LINES, 20 CHARACTERS EACH (INCLUDES SPACES)

\*CUSTOM LABEL FOR COVER: 2 LINES, 20 CHARACTERS EACH (INCLUDES SPACES)

Additional charge (separate line item) for custom labels. Custom label part # CUSTOM-LBL.  
Labeling on the bottom of the shell or the button head is available for an additional charge.  
Contact customer service for information.

Please call STI toll free or your local distributor after completing the worksheet to order the Stopper Station right for your needs.

# 800-888-4STI (4784)



**Safety Technology International, Inc.**

2306 Airport Road  
Waterford, Michigan  
48327, USA

Tel: 248-673-9898  
Fax: 248-673-1246  
Tollfree: 800-888-4STI  
info@sti-usa.com  
www.sti-usa.com

Unit 49G Pipers Road  
Park Farm Industrial Estate  
Redditch, Worcestershire  
B98 0HU England

Tel: 44 (0) 1527 520 999  
Fax: 44 (0) 1527 501 999  
Free: 0800 085 1678 (UK)  
www.sti-europe.com