

INSTALLATION AND OPERATING INSTRUCTIONS For Model GL1 Gate Locks

1. INTRODUCTION

Securitron's GL1 Gate Lock is an electromechanical lock designed for exterior (or interior) use in gated areas which require controlled access or egress. Each unit is comprised of a strong mounting chassis, access cover and an easy to install swivel type strike assembly that provides a very forgiving allowance for misalignment due to gate sag or tracking error (up to +/-1/2" vertically and horizontally from the centerline of the lock to the centerline of the strike). The unit operates at 12 Volts DC or 24 Volts DC and is fail safe / fail locked field-convertible.

QUICK NOTES:

- 1) See **SECTION 5.3** for information on optional Securitron mounting brackets (sold separately).
- 2) See **SECTION 6** for instructions on the Fail Safe trigger conversion.

2. SPECIFICATIONS

Physical:

Holding Force: 2,000 Lbs. [907 Kg]

Dimensions:

Inches: 2-3/4" L X 7-1/4" H X 3-1/4" D
Millimeters: 70 L X 184 H X 83 D

Electrical:

12 Volts DC Current Requirement:

Initial (Peak): (~1 sec.) 870 mA

Reduced: 290 mA

Power Consumption: 3.5 Watts

24 Volts DC Current Requirement:

Initial (Peak): (~1 sec.) 720 mA

Reduced: 170 mA

Power Consumption: 4.1 Watts

3. PRODUCT OVERVIEW

Upon unpacking this product, an inventory should be made to ensure that all the required components and hardware have been included. Along with these instructions and the installation template, the lock assembly should include the following items:

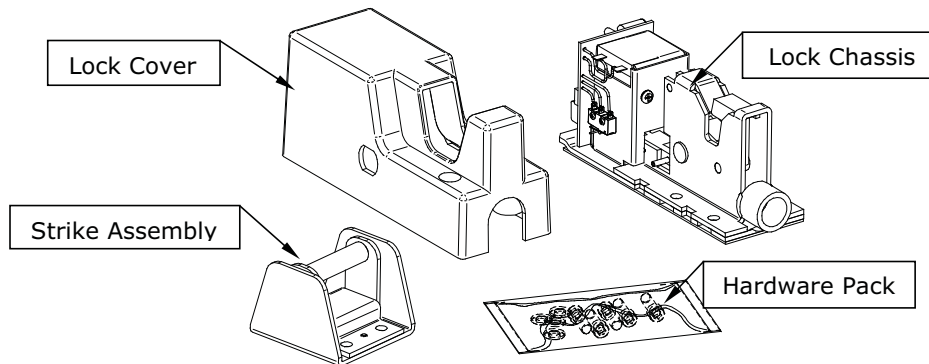

4. RECOMMENDED TOOLS

Hammer

Center punch

Drill

Drill bits: 25/64" [10mm] and 1/2"
[12.7mm], (13/64" [5.2mm] - Optional)

Wrenches: 1/2" box-end, 1/4" & 7/8" open-end or adjustable

Pliers, Vise grip

Screwdriver, #2 Phillips

Hex (Allen) wrench, 3/16" or 5mm

(Tap, 1/4-20 UNC-2B or M6-1.0 - Optional)

5. INSTALLATION INSTRUCTIONS

5.1. Pre-Installation Survey

Due to the variety of mounting configurations available with this product, it is strongly recommended that an initial physical survey and assessment be made of the actual area to which the lock will be installed. A determination of the optimal method of mounting should be made prior to installation with considerations made to the following:

A. Physical strength of mounting areas:

It is recommended that the structural integrity of mounting surfaces be strong enough to meet or exceed the holding force of the lock.

B. Protection of the lock from external attack:

The lock and the wiring must be protected to a reasonable degree from potential damage due to intruders or vandals.

C. Convenience and accessibility of area to be protected:

The lock assembly should be installed in a location that will not hinder or create a potential safety hazard to authorized personnel routinely accessing the protected area.

The mounting configurations primarily addressed in this manual will be for swinging and sliding gate applications. Fastening hardware required for mounting the lock and strike in either mount configuration has been included with the unit. For added security (in conjunction with the fasteners, the lock and strike may be welded in place (see **Figure 7**, page 6), but care must be taken when welding to prevent damage to the electronic components of the lock. Because of the diversity in gate manufacturing/construction methods and installation configurations, mounting surfaces for the lock and strike assembly will be left to the installer. Optimum mounting platforms may be achieved by welding adequate size metal plates, channels or tubing to the fence frame and the gate. Formed angle and brackets along with appropriately sized fasteners may also be utilized to mechanically secure mounting platforms for the lock and strike. For maximum security when using the provided blind nut inserts, it is best to mount the lock to steel tubing or channel in order to conceal and protect the backside of the nut from exposure to damage or vandalism.

INSTALLATION WARNINGS:

- 1. The lock must be mounted in the upright vertical or horizontal position.**
- 2. Make sure all welding is completed prior to making any electrical connections to the mounted lock. Welding in or around a lock assembly that is connected electrically can cause damage to the electronic components.**
- 3. Not recommended for dual swing gates.**

The following illustrations show some basic mounting configurations on a chain-link style fence frame and gate:

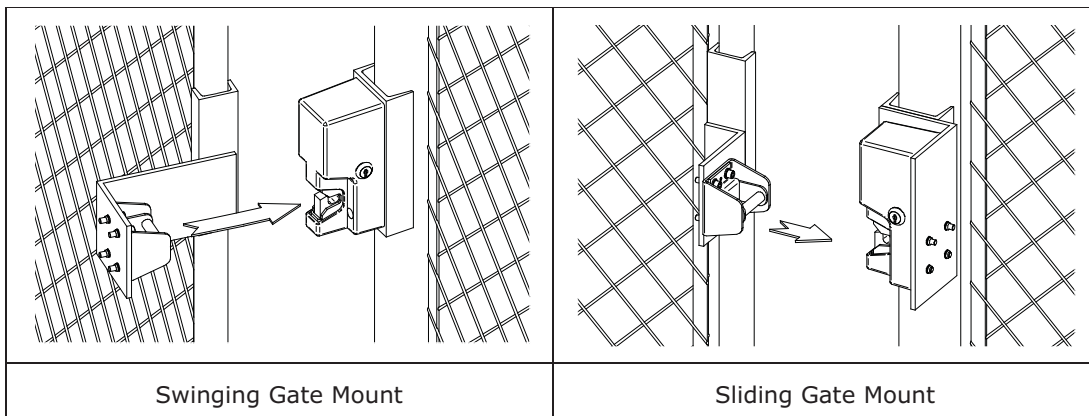

Typical Gate Lock Applications:

5.1.1. Swinging Gate

The following **Figures 1** through **4** demonstrate an example of a lock installed to a round tubular steel (chain-link) gate and frame in a swinging gate configuration. The mounting brackets shown are only examples – they are NOT included with the product:

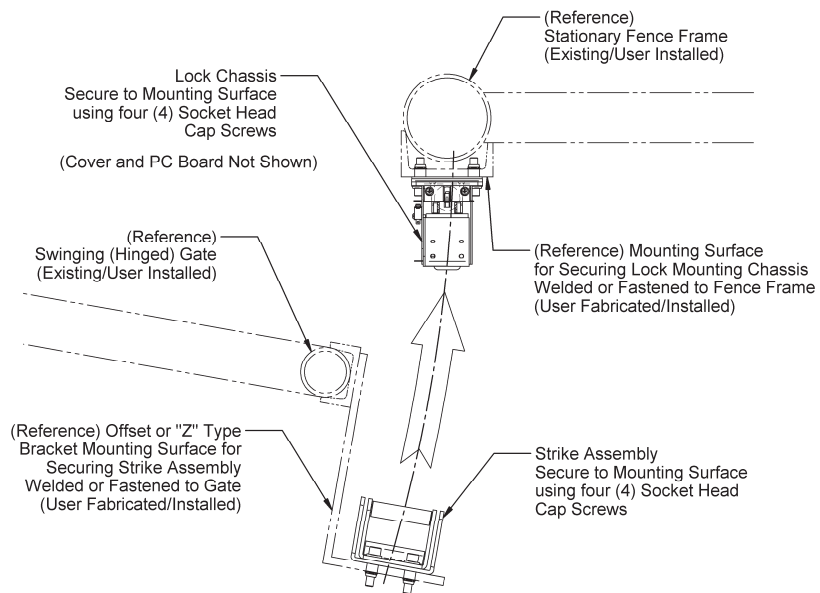

Figure 1 – Swing Gate Operation

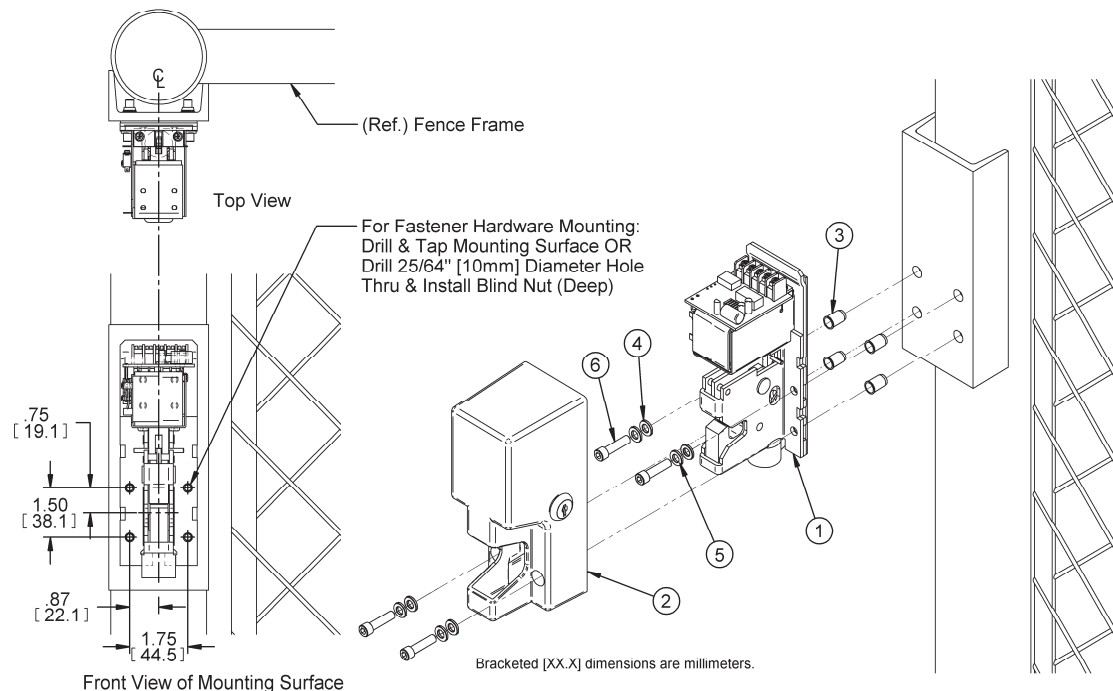

Figure 2 – Lock Installation

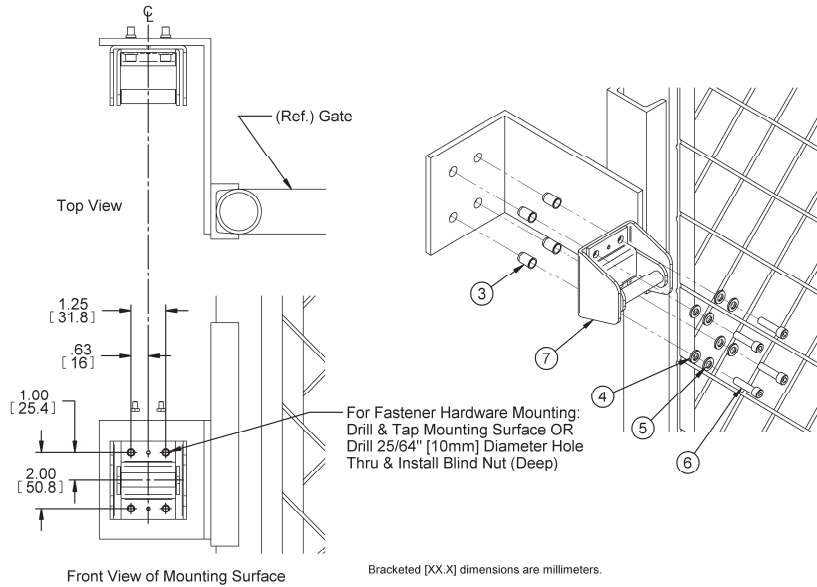

Figure 3 – Strike Installation

ITEM	QTY	DESCRIPTION
1	1	Lock Chassis
2	1	Lock Cover
3	8	Blind Nut (Deep), 1-Piece
4	8	Washer, Flat .06" Thick, Steel, (Z/P)
5	8	Washer, Split Lock, Steel
6	8	Socket Head Cap Screw, Steel (Z/P)
7	1	Strike Assembly
8	1	Thread Locking Compound

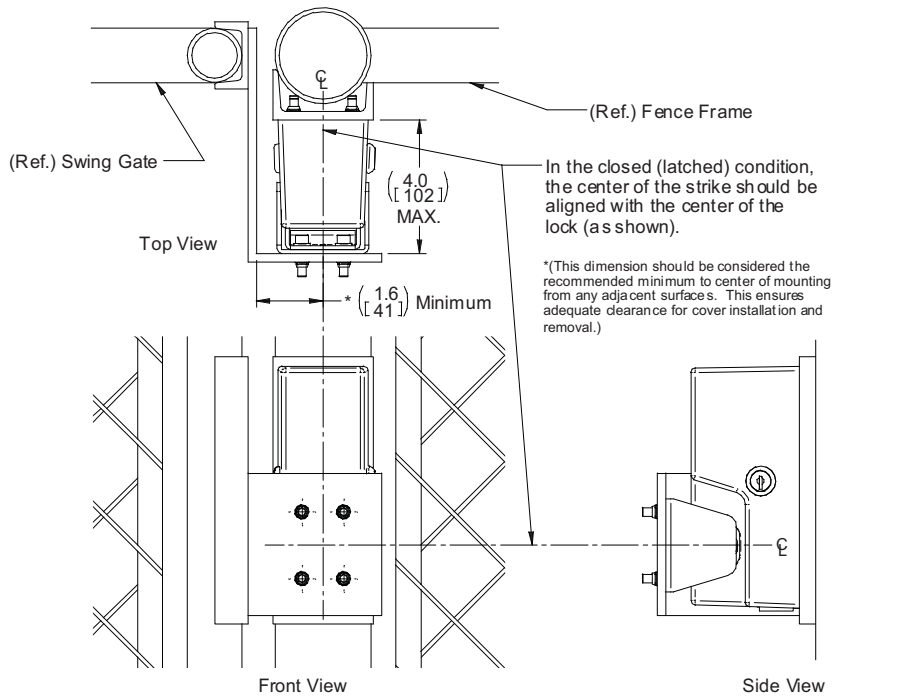

Figure 4 – Lock/Strike Alignment (Swinging Gate)

5.1.2. Sliding Gate

Figures 5 and 6 demonstrate an example of a lock installed to a round tubular steel (chain-link) gate and frame in a sliding gate configuration. The mounting brackets shown are only examples – they are NOT included with the product:

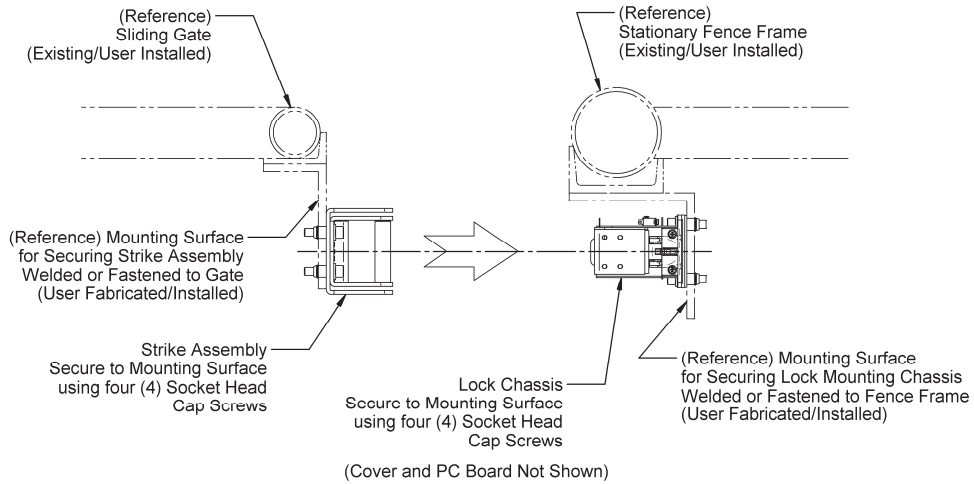

Figure 5 – Sliding Gate Operation

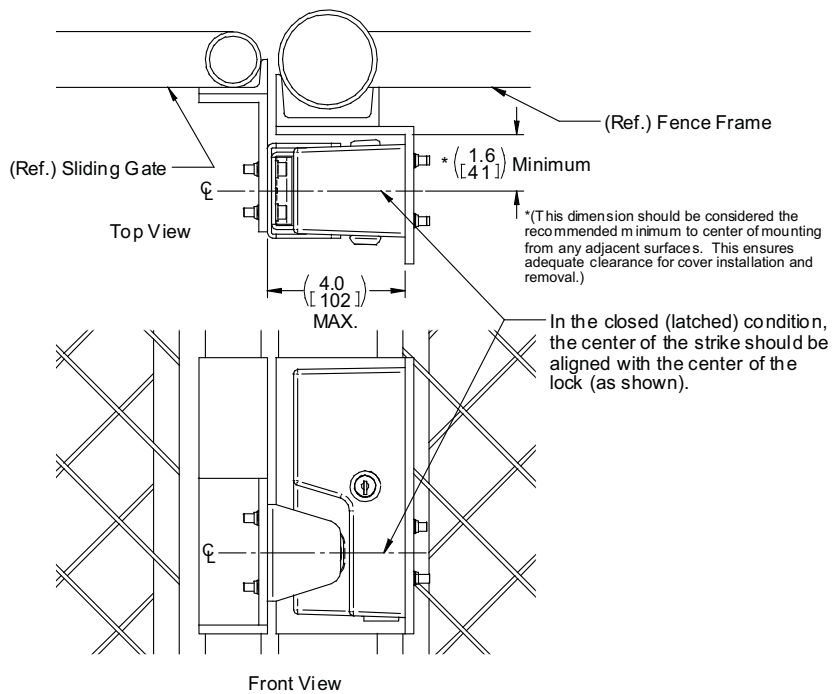

Figure 6 – Lock/Strike Alignment (Sliding Gate)

5.2. Lock Installation

5.2.1. Lock Chassis Installation

Use the *Gate Lock Installation Template* provided and the following step-by-step instructions to install the lock mounting chassis to the fence frame mounting surface.

1. Cut out the template and place into position on the fence frame lock mounting surface (plate or bracket) at the desired mounting location. **Note:** tape may be used to temporarily hold template in place. Mark and center punch the four (4) chassis mounting holes. If using the chassis rear wire access hole, mark and center punch its location also.
2. If drilling and tapping through the mounting surface for the mounting screws:
 - a. Drill four (4) holes of the appropriate tap drill size for the screws being used through the mounting surface at the marks for the chassis mounting holes.
 - b. Thread the holes using a tap.
3. If installing the provided blind nuts (Item #3) through the mounting surface:

Special Note: The blind nuts provided have a grip range of 3/16" [4.8mm] to 1/4" [6.4mm] and thus are intended for use in material of this thickness (gauge) range. If the thickness of the mounting surface to be used is under this range an alternate blind nut kit (**BN-250** or **BN-6MM**) is available through Securitron to accommodate the thinner gauge materials. It should be understood however, that mounting the lock to light gauge material will adversely affect the holding strength of the lock and is NOT recommended.

 - a. Drill four (4) 25/64" [10mm] diameter holes through the mounting surface at marks for chassis mounting holes.
 - b. Install blind nuts into the 25/64" [10mm] diameter holes in the mounting surface as follows:
 - c. Using blind nut collapsing tool provided (with blind nut in place), insert the end of the blind nut into the hole.
 - d. Using a hammer (if necessary) tap until the nut upper lip seats against the mounting surface.
 - e. While holding the hex portion of the collapsing tool with a 1/2" box-end wrench or vise grip pliers, turn the socket head cap screw of the tool using a 3/16" (or 5mm) hex wrench. **Note:** Maintain firm pressure toward the mounting surface while collapsing the nut.
 - f. Once the blind nut is adequately collapsed, remove the tool from the nut by backing the cap screw out of the blind nut thread.
 - g. Install the subsequent blind nut(s) onto the collapsing tool (cap screw) and repeat steps 3c through 3f.
4. If the optional rear wire access hole is to be used, drill one 1/2" [12.7mm] diameter hole through the mounting surface (see installation template).
5. Install the lock mounting chassis (**Item #1**) into place using two (2) socket head cap screws (**Item #6**), two (2) split lock washers (**Item #5**) and two (2) flat washers (**Item #4**) **through the upper two holes of the chassis only.** **Note:** It is recommended that thread locking compound (**Item #8**) be applied to these two (2) cap screw threads at this point. Fully tighten the screws using a hex wrench.

Note: For maximum security, the lock chassis may be welded into place **in addition to** the fastener mounting. The lock chassis features four (4) "pockets" (two per side) that may be used for welding purposes (See **Figure 7**). **Welding must be confined to these pockets and flush with the edges of the chassis for proper fit of the lock cover.** (See *Section 5.1 Pre-Installation Survey* for additional welding precautions).

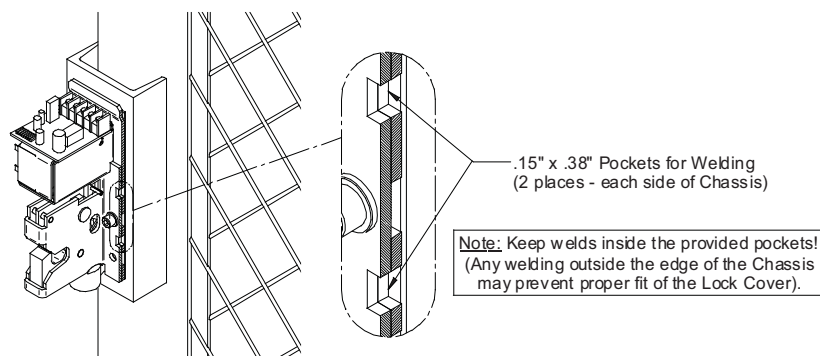

Figure 7 – Welding Pockets

5.2.2. Strike Installation

Use the installed lock chassis for alignment/reference, the provided template, and the following instructions to position and install the strike assembly to the gate mounting surface.

1. Prepare the gate by welding/installing mounting surface(s)/bracket(s) into position that will provide the correct alignment and spacing for proper function between the mounted lock and strike assembly.
2. Cut out the strike mounting template and place into position on gate/frame mounting surface at the desired location. Mark and center punch the four (4) strike mounting holes.
3. Drill and tap as described in the previous section (5.2.1 Lock Chassis Installation - Step 2) **or** Drill four (4) 25/64" [10mm] diameter holes through the mounting surface (for blind nuts) at the marks for the strike mounting holes.
4. If blind nuts (**Item #3**) are used, install them into the 25/64" [10mm] diameter holes in the mounting surface as described in the previous section (5.2.1 Lock Chassis Installation - Step 3c through 3g).
5. Install the strike assembly (**Item #7**) to its mounting surface using four (4) socket head cap screws (**Item #6**), four (4) split lock washers (**Item #5**) and four (4) flat washers (**Item #4**).

Note: It is recommended that thread locking compound (**Item #8**) be applied to the cap screw threads at this point. Fully tighten the screws using a hex wrench.

Note: As with the lock chassis, for maximum security, the strike assembly may be welded into place **in addition to** the fastener mounting.

5.2.3. Manual Override/Cover Hole Plug Installation

The Gate Lock provides for the additional function of a key operated (cam type) manual override for use when the lock is operated in the **fail locked mode**. The key operated cam lock can be assembled to either side of the lock cover. **Figure 8** and the following instructions describe the proper installation of the cam lock and the cam lock hole plug.

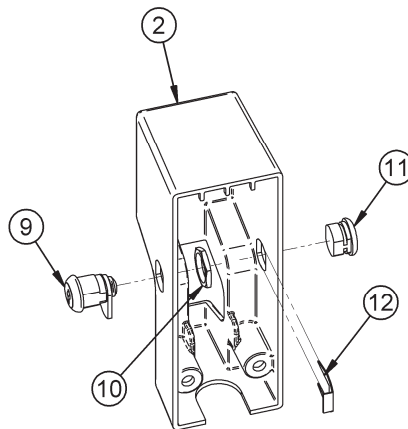

Figure 8 – Cam Lock & Plug Installation

ITEM	QTY	DESCRIPTION
2	1	Lock Cover
9	1	Cam Lock (Manual Override)
10	1	Hex Nut, Cam Lock Mounting
11	1	Plug, Cam Lock Hole
12	1	Spring Clip, Cam Lock Hole Plug

Manual Override Cam Lock Installation:

1. If it is desired to implement the manual override, select the side of the lock cover that will be the most convenient for the key access after installation. (The Gate Lock latching mechanism features an actuator lever that will engage the cam lock from either side of the cover).
2. Install the provided cam lock (**Item #9**) so that when the cylinder is in the key-out position the cam points down. Assemble the cam lock as necessary so that the key rotation moves the cam to point toward the rear (opening) of the cover. **Note:** This is critical to the proper operation of the mechanical override function. The rear cam of the lock must come into contact with the actuator lever pin to operate the release trigger of the lock mechanism when the cover is assembled to the lock chassis.
3. Slip the cam lock mounting hex nut (**Item #10**) over the cam inside the cover and thread the nut onto the cam lock body by hand (See **Figure 8**).
4. Using a 7/8" open-end (or adjustable) wrench, tighten to secure the hex nut in place.

Note: If the manual override is not used:

- a. Install the cam lock through the non-accessible hole of the cover and install the hex nut as directed in steps 3 and 4 (above).
- b. Assemble the cover hole plug (provided) through the side that is accessible as directed in the following *Cam Lock Hole Plug Installation* instructions.

Cam Lock Hole Plug Installation:

1. Insert the cam lock hole plug (**Item #11**) through the desired hole in the lock cover (See **Figure 8**).
2. Slide the spring clip (**Item #12**) along the inside wall of the cover and into the grooves of the plug to secure.

5.2.4. Fail Locked and Fail Safe Modes

The GL1 Gate Lock, as delivered from the factory, is configured to operate in one of two power failure modes:

Fail Locked Mode:

In this mode, at loss of power, the lock's latching mechanism will lock when the gate is closed and remain in the latched/locked condition until power is restored or the mechanism is disengaged by the manual override.

Fail Safe Mode:

In the fail safe configuration, when there is a loss of power to the lock, the latching mechanism will not lock when the gate is closed and will unlock if the gate was previously secured.

Each unit can be converted from the fail locked to the fail safe mode (or fail safe to fail locked) as required. If this is necessary, follow the step-by-step instructions provided in *Section 6 GL1 Fail Locked to Fail Safe Trigger Conversion*.

Note: The manual override is non-functional in the fail safe mode.

5.2.5. Chassis Final Installation

Using the following instructions complete the installation of the lock mounting chassis to the fence frame.

1. Verify that all necessary welding has been completed.
2. Route all electrical wiring through either the wire conduit coupling provided in the bottom of the chassis or through the optional 1/2" (12.7mm) hole in the rear of the lock mounting chassis (See **Figure 9**). **Note:** If the conduit coupling is not used, a 1/2"-14 NPS conduit or pipe plug should be installed and tack-welded into place to close the fitting.
3. Feed wires through the obround hole in the right side of the lock mounting chassis.

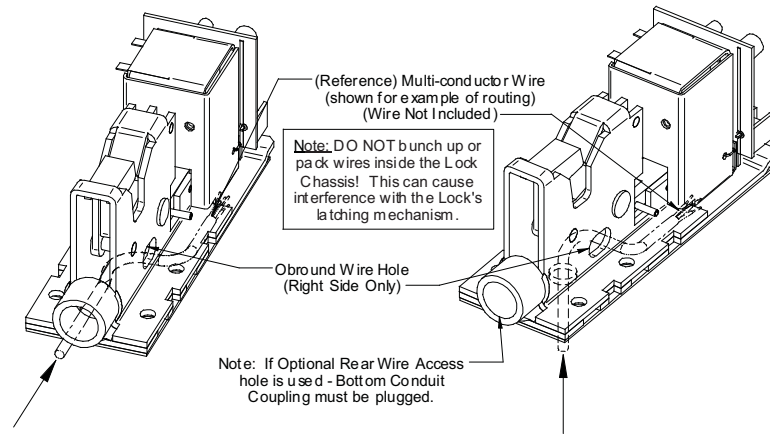

Figure 9 – Wire Routing

4. Make all necessary wire connections at the terminal block on the PC Board. See *Section 7 Operational Instructions* for electrical wiring diagrams.

Note: Ensure wiring does not interfere with the manual override (cam lock) if it is installed to the right side of the lock.

5. After the electrical wiring has been completed, install the lock cover (**Item #2**) over the lock mounting chassis (**Item #1**) by engaging the lip at the top/rear of the cover with the top edge of the mounting chassis. Secure the cover to the mounting surface using two (2) socket head cap screws (**Item #6**), two (2) split lock washers (**Item #5**) and two (2) flat washers (**Item #4**). Fully tighten the screws using a hex wrench.

5.3. Installation Recommendations and Assistance

As previously mentioned, special brackets (mounting surfaces) will most likely be required for mounting this lock system to the various fence/gate configurations in existence. It is recommended that whenever possible, suitable mounting surfaces be welded to the fence/gate structure. Mounting bracket kits such as the **FMK-SL** (Sliding Gate) and the **FMK-SW** (Swing Gate), and advanced instructions required for some installations are available through Securitron Maglock Corporation or one of our authorized representatives.

6. GL1 FAIL LOCKED TO FAIL SAFE TRIGGER CONVERSION

Mount unit before initiating conversion of unit.

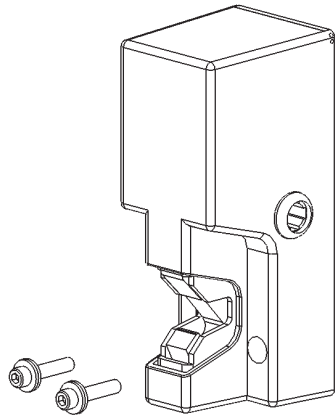

Disconnect power from the GL1 and control device.

Ensure that the gate is secured in an open position so it cannot close and injure the operator.

Remove the cover from the GL1 by removing the two screws.

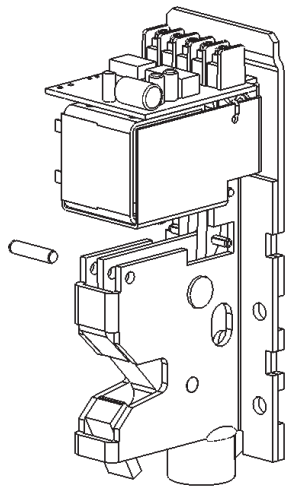

Using a small screwdriver or punch to start it moving, remove the Trigger Pin.

Grab the Trigger with one hand and hold the Transfer Bar back by pressing on the long roll pin with the other hand.

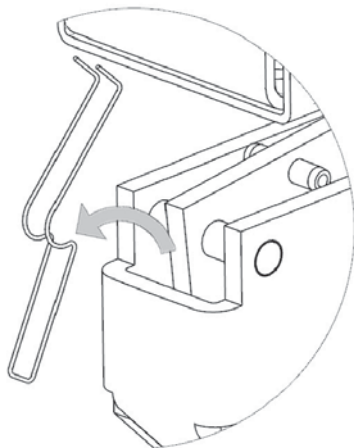

Remove the legs of the spring from under the roll pin in the trigger. Remove the spring from the front of the chassis. **DO NOT LOSE THE SPRING.**

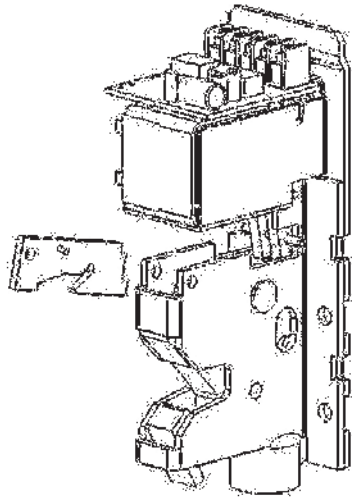

Pull the Trigger out the front of the lock Chassis.

You may need to move the Catch (hook) back and forth to clear the slot on the bottom of the Trigger.

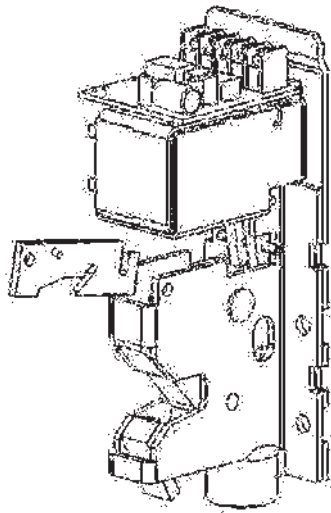

Insert the new Trigger into the lock Chassis.

The back of the Trigger must fit in the center slot of the Transfer Bar and UNDER the pin.

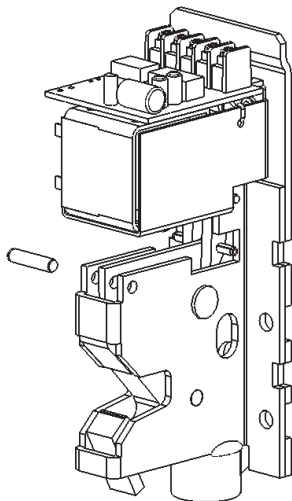

You may need to move the Catch (hook) up/back to get the Trigger into position where the pivot pin hole lines up with the holes in the Chassis.

Reinstall the pivot pin and check to make sure all wires clear the Cover and Transfer Bar cross pin.

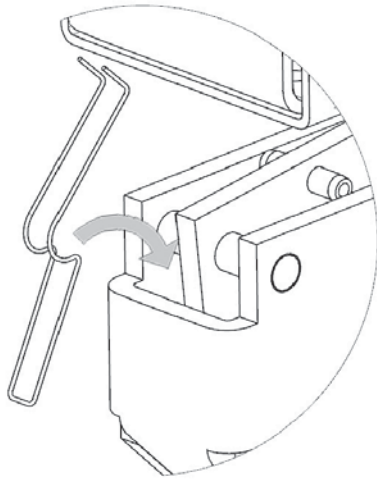

The spring fits behind the front wall of the chassis as shown and the spring legs go on the sides of the trigger.

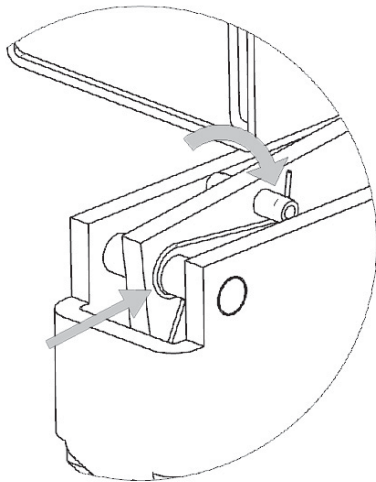

Hook the loops of the spring under the trigger hinge pin as illustrated.

Use needle nose pliers to bend the legs of the spring under the cross pin in the trigger.

Replace the Cover and test for correct operation.

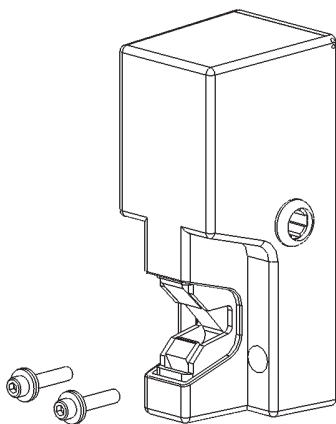

USE THIS SAME PROCEDURE FOR FAIL SAFE TO FAIL SECURE CONVERSION.



7. OPERATIONAL INSTRUCTIONS

The Gate Lock is a direct latching fail safe/locked electromechanical lock which incorporates Securitron's unique dual voltage system. The GL1 **does NOT** automatically re-lock if the strike is not moved from the latch. The **strike must always be pushed closed** to mechanically re-latch in order for the GL1 to re-lock.

In Fail Locked mode: Applying input voltage of 12 or 24 volts DC, observing polarity (See **Figure 10**), will energize and **unlock** the Gate Lock allowing the gate to be opened. Removing the input voltage will de-energize the Gate Lock and will allow it to mechanically latch secure when the gate is closed.

In Fail Safe mode: The input voltage must be maintained to keep the Gate Lock in a **locked** mode. Removing the input voltage will de-energize and **unlock** the Gate Lock allowing the gate to be opened. Applying input voltage will energize and **lock** the Gate Lock awaiting the gate to be closed.

Additionally, the Gate Lock includes a gate status sensing feature indicating whether the gate is closed or open. When the gate (strike assembly) is latched closed the Gate Lock will report this closed condition by outputting a closed circuit condition between the C and NC terminals. When the gate is open, the closure will be between the C and NO terminals. This dry Single Pole Double Throw (SPDT) output can carry **1 Amp @ 30VDC maximum**.

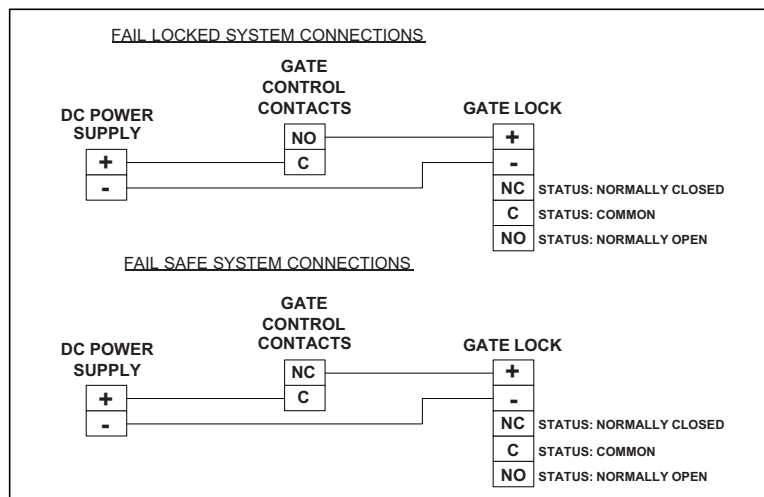

Figure 10 – Wiring Diagram

8. MAINTENANCE

To keep the lock in top working order, (especially a lock being used outdoors in extreme climate conditions), we recommend periodically taking a clean cloth and cleaning solvent and wiping down the lock mechanism and the strike assembly then applying new lubricant to the lock's latch and pivoting parts.

9. APPENDICES

A. WIRE GAUGE SIZING

If the power supply is distant from the lock, voltage will be lost (dropped) in the connecting wires so that the lock will not receive full voltage. The following chart shows the minimum wire gauge that will hold voltage drop to an acceptable level for different lock to power supply distances. Proper use of the chart assumes a dedicated pair of wires to power each lock (no common negative). Also note that the correct calculation of wire sizing is a very important issue as the installer is responsible to insure that adequate voltage is supplied to any load. In multiple device installations, the calculation can become quite complex so refer to the following section "Calculating Wire Gauge Sizing" for a more complete discussion.

Distance	Gauge 12V	Gauge 24V	Distance	Gauge 12V	Gauge 24V
100 FT	20 GA	22 GA	800 FT	12 GA	14 GA
200 FT	18 GA	20 GA	1500 FT	10 GA	10 GA
400 FT	14 GA	16 GA	2000 FT	8 GA	8 GA

CALCULATING WIRE GAUGE SIZING

The general practice of wire sizing in a DC circuit is to avoid causing voltage drops in connecting wires that reduce the voltage available to operate the device. As Gate Locks are low power devices, they can be operated long distances from their power source. For any job that includes long wire runs, the installer must be able to calculate the correct gauge of wire to avoid excessive voltage drops.

This is done by taking the current draw of the lock and multiplying by the resistance of the wire $I \times R = \text{Voltage drop}$ (i.e. $0.7 \text{ Amp.} \times 1.6 \text{ Ohms} = 1.12 \text{ Volts}$ dropped across the wire). For all intents and purposes it can be said that a 5% drop in voltage is acceptable so if this were a 24 Volt system ($24 \text{ Volts} \times .05 = 1.2 \text{ Volts}$) a 1.12 Volt drop would be within tolerance.

To calculate the wire resistance, you need to know the distance from the power supply to the lock and the gauge (thickness) of the wire. The following chart shows wire resistance for solid copper wire per 1000 ft (305 meters):

Wire Gauge	Resistance/1,000 ft	Wire Gauge	Resistance/1,000 ft
8 Gauge	.6 Ohms	16 Gauge	4.1 Ohms
10 Gauge	1.0 Ohms	18 Gauge	6.4 Ohms
12 Gauge	1.6 Ohms	20 Gauge	10.1 Ohms
14 Gauge	2.5 Ohms	22 Gauge	16.1 Ohms

B. RECOMMENDATIONS FOR MAXIMUM PHYSICAL SECURITY

The Gate Lock carries a rated holding force of 2,000 lbs. [907 Kg]. There are several installation and application variables to be considered which affect the security level that may be obtained while using this lock.

Mounting the lock on the secure side of the gate is an important factor that will contribute to its protection from attack/vandalism.

This lock is designed to be mounted using the included fasteners which exceed the strength of the lock. Installed strength can additionally be enhanced by welding the lock/strike to suitable steel mounting surfaces. If any of the factory included fasteners or hardware are substituted for any reason, the strength of the mounting system may be compromised. Use of sheet metal screws in the installation of this lock is not recommended. The lock receives an impact and torque force each time that the gate is opened and closed, which over time will work the sheet metal screws loose.

To fully complete an installation that maximizes the effectiveness of the included fasteners, the thread locker compound (provided) should be used to help prevent the screws from loosening over time.

C. TROUBLESHOOTING

PROBLEM: The lock does not latch.

- Check lock-to-strike engagement distance...Strike may be mounted too far away from the lock (see **Figure 4** or **6**, page 4 or 5).
- Check wire routing...Ensure wiring does not impede the function of the lock mechanism (manual override/actuator lever, or behind lock catch – see pages 9 and 11).
- For fail safe models – Ensure that there is power supplied to the unit and that the lock is wired correctly (see pages 13 and 14).

PROBLEM: The lock output does not report secure condition.

- Check wiring...Ensure wires are connected to the appropriate terminals (see **Figure 10**, page 13).
- Check status of lock/strike...Verify that lock and strike are physically latched.

PROBLEM: The lock does not release.

- Check for excessive pre-load to lock...The Gate Lock latching mechanism is not designed to release under pre-loads in excess of 100 lbs. (fail locked only).
- Check incoming voltage at the lock...
 - For fail locked models electrical power is required to energize and release the lock - Verify that there is power to the lock and that the voltage being delivered is within the operating specifications (see pages 1, 13 and 14).
 - For fail safe models electrical power is removed to de-energize and release the locking mechanism - Verify that the power to the lock has been terminated (see pages 13 and 14).
- Check wire routing...Ensure wiring does not impede the function of the lock mechanism (manual override/actuator lever – see pages 9 and 11).

PROBLEM: Cover does not fit on the lock.

- Check welding...If the lock chassis was welded to the mounting surface; verify that there are no welds that extend beyond the edge of the chassis (back plate) (see **Figure 7**, page 6).
- Check wire routing...Ensure that the placement of the wires is not inhibiting the proper fit of the cover to the lock chassis.

PROBLEM: Manual override does not work.

- Check cover...Make sure that the lock cover is fully seated and securely fastened in place.
- Check cam lock installation...Verify that the cam lock is correctly installed and functions properly – review installation instructions and check rotation direction (see pages 7 and 8).
- Check wire routing...Ensure that the placement of the wires does not impede the rotation of the cam or movement of the latching mechanism (see pages 9 and 11).

**IF YOUR PROBLEM PERSISTS
CALL SECURITRON TOLL FREE
1-800-MAG-LOCK**

MAGNACARE® LIMITED LIFETIME WARRANTY

SECURITRON MAGNALOCK CORPORATION warrants that it will replace at customer's request, at any time for any reason, products manufactured and branded by SECURITRON.

SECURITRON will use its best efforts to ship a replacement product by next day air freight at no cost to the customer within 24 hours of SECURITRON's receipt of the product from customer. If the customer has an account with SECURITRON or a valid credit card, the customer may order an advance replacement product, whereby SECURITRON will charge the customer's account for the price of the product plus next day air freight, and will credit back to the customer the full amount of the charge, including outbound freight, upon SECURITRON's receipt of the original product from the customer.

SECURITRON's sole and exclusive liability, and customer's sole remedy, is limited to the replacement of the SECURITRON product when delivered to SECURITRON's facility (freight and insurance charges prepaid by customer). The replacement, at SECURITRON's sole option, may be the identical item or a newer unit which serves as a functional replacement. In the event that the product type has become obsolete in SECURITRON's product line, this MAGNACARE warranty will not apply. This MAGNACARE warranty also does not apply to custom, built to order, or non-catalog items, items made by others (such as batteries), returns for payment, distributor stock reductions, returns seeking replacement with anything other than the identical product, or products installed outside of the United States or Canada. This MAGNACARE warranty also does not apply to removal or installation costs.

SECURITRON will not be liable to the purchaser, the customer or anyone else for incidental or consequential damages arising from any defect in, or malfunction of, its products. SECURITRON does not assume any responsibility for damage or injury to person or property due to improper care, storage, handling, abuse, misuse, or an act of God.

EXCEPT AS STATED ABOVE, SECURITRON MAKES NO WARRANTIES, EITHER EXPRESS OR IMPLIED, AS TO ANY MATTER WHATSOEVER, INCLUDING WITHOUT LIMITATION THE CONDITION OF ITS PRODUCTS, THEIR MERCHANTABILITY OR FITNESS FOR ANY PARTICULAR PURPOSE.

PATENTS

Securitron's Gate Lock is Patent Pending.